

Coffee House

ABE
EQUIPMENT

ABE Equipment offers coffee brewhouses between 155 gallons and 1,860 gallons for your cold brew needs. All coffee brewhouses are equipped with a control box that meets CSA/UL and EU standards. Each coffee brewhouse comes standard with a lasered 280 or 400 micron, stainless-steel false bottom and an optional secondary filter containing a nylon bag with your choice of micron size. Coffee houses come standard with a rake and plow system for easy agitation and automatic spent-ground removal. All ABE Equipment coffee brewhouses come equipped with jackets for brewing hot or cold.

Designed for Ease of Use

- Control box includes controls for temperature, pump, light, rake, and plow
- Stainless steel CIP high-flow rotary spray ball
- Stainless steel, piping, valves, clamps, fittings, and washdown pump
- Rake and plow system for spent ground removal

Detail Oriented

- Lasered 280 or 400 micron stainless steel false bottom
- Stainless steel filter housing with a nylon filter bag
- Sight tube with a sample port
- Thermo-well and temperature probe
- Recirculation Arm

Filtration

- Secondary 35 gallon external filter
- Casters and frame included for increased mobility
- Various micron bags available



ABE
EQUIPMENT

VINIQUIP

Coffee House

General Specifications

- System dimensions: Height: 101 inches (257 cm), Length: 90 inches (229 cm), Width: 73 inches (186 cm)
- Electrical requirements: 208V, 60Hz, 3 Phase, 3 wire, 30 amp, 23 amp (Connected Load), 8.2 KVA, 6.8 KVA Average (other electrical options available)
- Glycol requirements: 5-10 GPM

Additional Features

- Internal LED lights
- UFD motor on rake/plow
- Coffee ground hydrater included

Your Complete Package

Each Coffee House that leaves our facility carries UL certification and an industry-leading five year limited warranty on the metal and welds. In addition to a comprehensive spare parts inventory, you'll receive superior customer support from our team in Lincoln, Nebraska with any ABE purchase.

Compatible Products

- CraftCan Canning Lines
- Cellar Tanks
- Bottling Lines
- Keg Washer

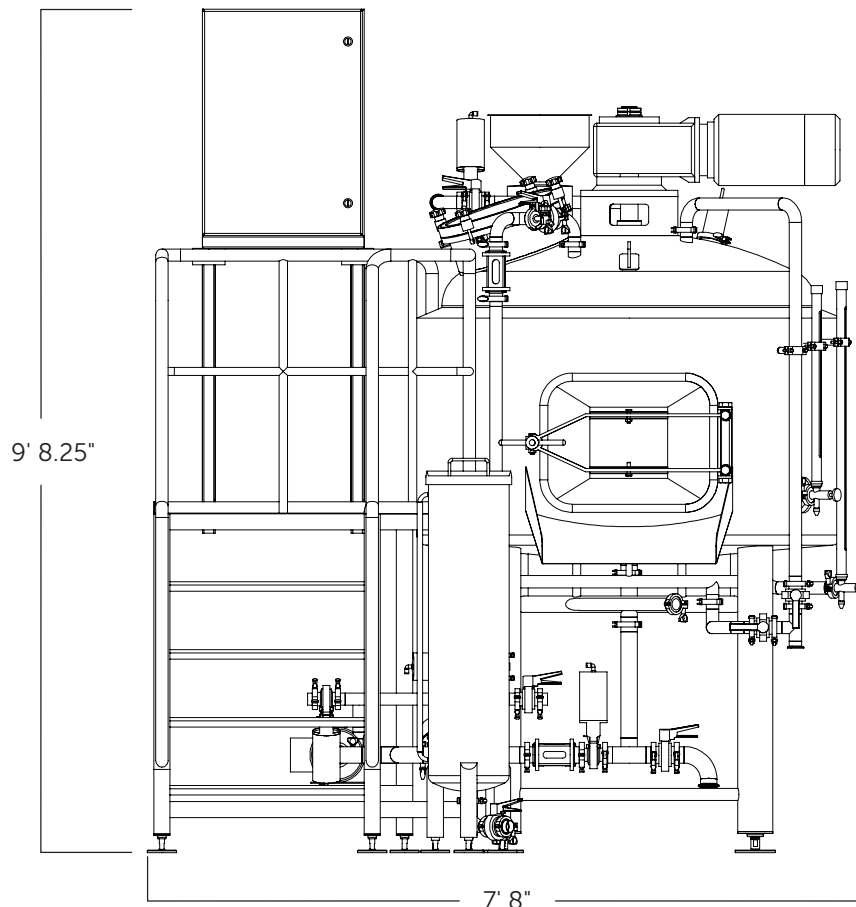

ABE Equipment reserves the right to change specification without notice. All specifications are approximate (+10). ©2022 ABE Equipment