



Delta ELVTR 300 / 400



Delta ELVTR 300

The mobile belt elevator Delta ELVTR enables:

- To feed presses, destemmers, sorting tables, maceration tanks... with **fresh grapes**.
- To feed presses with **macerated grapes**.
- To evacuate **stems and dried pomace**.

Delta ELVTR 300 and Delta ELVTR 400 assets

- Trolley with hydraulic lever.
- Cleaning rubber below belt.
- Quick release of the belt.

Robustness

- Exposed stainless steel framework of 304L – folded sheet thickness 20/10 – sand-blasted.
- Belt with curved brackets width: 300 mm / Height 60 mm or 400 mm / Height 80 mm, depending on material to be transferred.
- Double-folded stiff belt – in compliance with the FDA Food Approval – with stainless steel staples.
- On/Off button with a heat-proof system of the engine + 10 m. of wire.
- Drum motor on the top.

Adaptability

- Inclination of elevators is adjustable from 30° to 50° max. by means of hydraulic cylinders and manual pump.
- Trolley with 4 stainless steel DN 160 tilting wheels with brakes – polyurethane shrouding.

Easy cleaning

- Exposed stainless steel framework giving way to below belt.
- Floor with tubular profil.
- Cleaning rubber of below belt.
- Quick release system.

Options

- Reception hopper under Delta E 2 destemmer.
- Reception hopper under tank door (height: 500 mm).
- Hopper for screw conveyor (minimum height: 450 mm.).
- Reception hopper at the end of belt or vibrating table.
- High capacity reception hopper of 1200 x 1000 mm.
- Dismounting of hoppers by means of a quick system of clippers.
- Motor equipped with a frequency variator.
- Directional gully with swivel length 1000 or 1500 mm.
- Integrated cleaning rail of return belt.
- Flexible hose outlet length 700 mm.

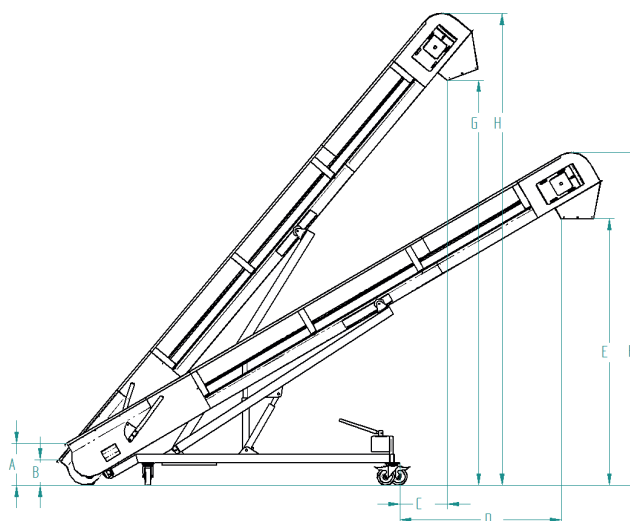

	A	B	C	D	E	F	G	H
2.5 m	396	235	301	847	1100	1720	1825	2444
3 m	396	237	114	773	1332	1952	2200	2820
3.5 m	415	244	469	1286	1399	2028	2553	3173
4 m	424	244	346	1290	1609	2238	2932	3552
4.5 m	425	236	118	1152	1806	2436	3358	3977
5 m	425	236	721	1703	2015	1645	3742	4361
5.5 m	419	229	323	1716	2176	2807	4098	4718
6 m	419	229	646	2172	2381	3012	4481	5100
6.5 m	414	247	618	2060	2659	3288	4694	5316
7 m	401	265	430	1697	3103	3726	4885	5507
7.5 m	407	234	430	2197	3214	3839	5570	6191
8 m	408	235	765	2652	3421	4047	5941	6562

Distributed by:

Bucher Vaslin

Rue Gaston Bernier – BP 70028
F - 49290 Chalonnes sur Loire
Tél. +33 (0)2 41 74 50 50
Fax +33 (0)2 41 74 50 51
E-mail : commercial@buchervaslin.com

www.buchervaslin.com
Your success is our priority